

Audio-Video Switch

HA11508 is an input signal switching IC designed for use in color televisions with external input terminals.

HA11508 provides switching operations for three video input circuits, three 2-channel audio circuits, and two output circuits.

Functions

- Video signal switching
- Audio signal switching
- Audio mute function

Features

- Signal switching for three video input circuits, three 2-channel audio input circuits, and two output circuits.
- Approximately 6dB on-chip amp in video switching section
- On-chip audio mute circuit
- High input impedance
- Wide frequency band
- High supply
- Can be used with 8 to 13.2 V supply voltages

Pin Arrangement

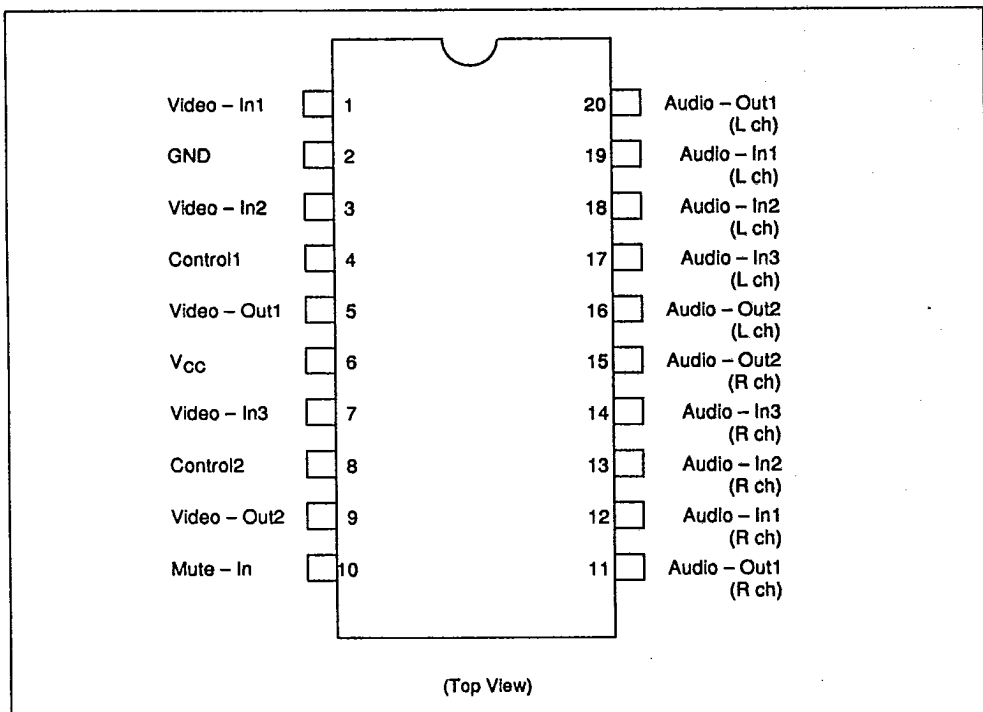

Block Diagram

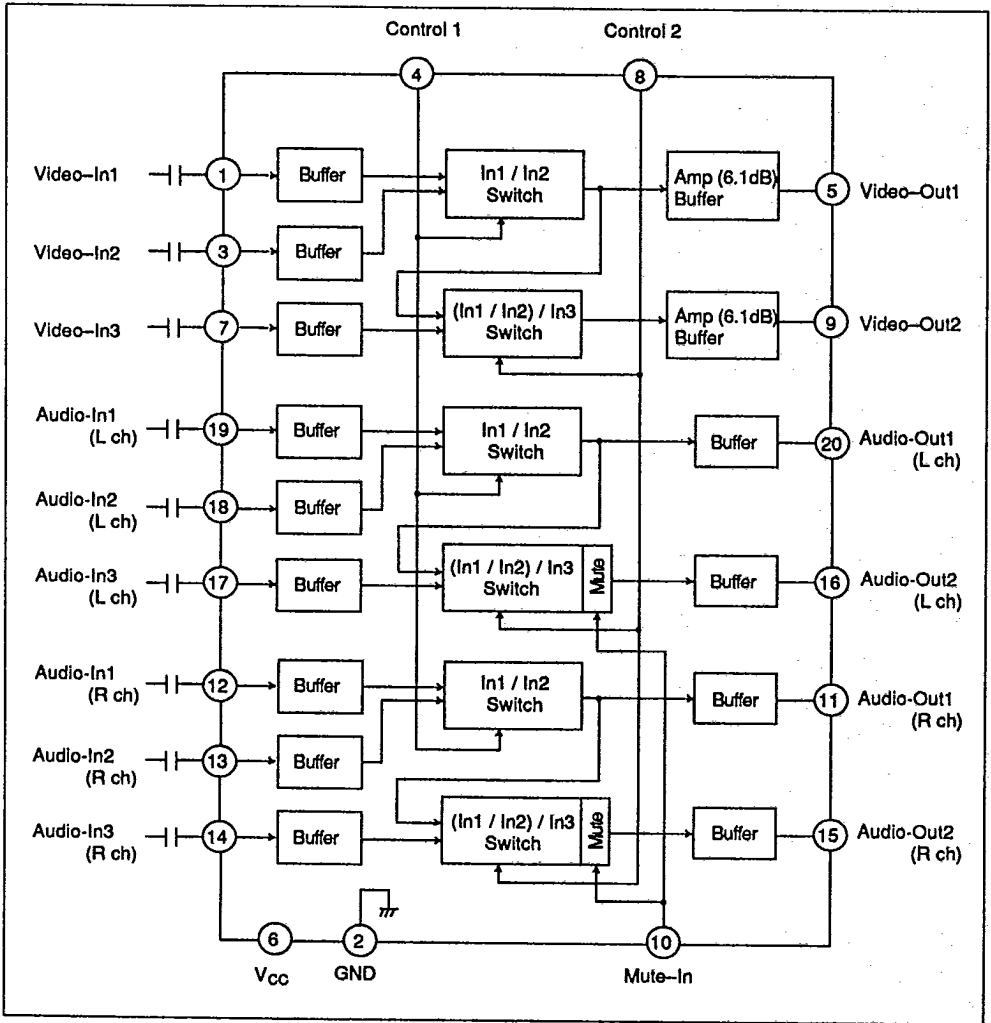

Absolute Maximum Ratings

Item	Symbol	HA11508	Unit
Supply Voltage	V_{cc}	14.4	V
Power Dissipation	P_T	550	mW
Operating Temperature	T_{opr}	-20 to +70	°C
Storage Temperature	T_{stg}	-55 to +125	°C
Control Terminal voltage		14.4	V

Note: Recommended supply voltage range: 8 to 13.2 V

Ordering Information

Type No.	Package
HA11508	DP-20



Electrical Characteristics (Ta = 25°C)

 (V_{CC} = 12V unless otherwise specified)

Item		Symbol	Min	Typ	Max	Unit	Test Condition
Supply Current		I _{CC}	18.0	22.5	30.0	mA	
Voltage Gain	Video	G _{VV}	5.6	6.1	6.6	dB	V _{in} V = 1V _{p-p} (sine wave) f = 0.1MHz
	Audio	G _{Va}	-0.2	-0.02	0	dB	f = 0.1kHz V _{in} A = 500mVrms
Frequency Band	Video	B _{wv}	10	-	-	MHz	V _{in} V = 0.7V _{p-p} (sine wave) -3dB bandwidth for 0.1MHz
	Audio	B _{wa}	100	-	-	kHz	-1dB bandwidth for f = 1kHz gain V _{in} A = 500mVrms
Total Harmonic Distortion		THD	-	0.005	0.2	%	f = 1kHz V _{in} A = 500mVrms
Output Noise Voltage	Video	V _{nv}	-	0.3	-	mVrms	R _g = 75Ω Bandwidth = 10MHz
	Audio	V _{na}	-	10	-	mVrms	R _g = 600Ω Bandwidth = 20 to 20kHz
Output DC Offset Voltage	Video	ΔV _{odv}	-50	0	50	mV	
	Audio output 1	ΔV _{odv1}	-20	0	20	mV	
	Audio output 2	ΔV _{odv2}	-40	0	40	mV	
Audio L-to-R Voltage Gain Difference		G _{Va1}	-0.2	0	0.2	dB	f = 1kHz V _{in} A = 500mVrms
Crosstalk	Video	C _{tV}	-	50	-	dB	R _g = 75Ω f = 3.58MHz
	Audio 1-to-2	C _{1a}	-	90	-	dB	R _g = 4.7kΩ f = 1kHz V _{in} A = 500mVrms
	Audio L-to-R	C _{1as}	-	82	-	dB	Same as above
Mute Residual Sound		V _{oam}	-	0.02	0.1	mVrms	f = 1kHz V _{in} A = 500mVrms
Mute Operation Output DC Offset Voltage		ΔV _{oam}	-	0	40	mVrms	Audio output 2 offset voltage
Input Signal Amplitude(Video input)		V _{in} V	-	1.0	-	V _{p-p}	From sync peak until 100% white
Switching Control Input Threshold Voltage		V _{th}	1.1	1.4	1.7	V	
Mute Input H Threshold Voltage		V _{thm}	1.1	1.4	1.7	V	



Switch Table

T-77-07-0

The following table shows the relationships between the IC signal input in accordance with switching control input 1 and 2, and the mute input control signal.

No.	Switching control input			Video signal output		Audio signal output**	
	Mute	1	2	Output 1	Output 2	Output 1	Output 2
1	L	L	L	Input 1	Input 1	Input 1	Input 1
2	L	L	H	Input 1	Input 3	Input 1	Input 3
3	L	H	L	Input 2	Input 2	Input 2	Input 2
4	L	H	H	Input 2	Input 3	Input 2	Input 3
5	H	L	L	Input 1	Input 1	Input 1	-
6	H	L	H	Input 1	Input 3	Input 1	-
7	H	H	L	Input 2	Input 2	Input 2	-
8	H	H	H	Input 2	Input 3	Input 2	-

*1 Audio signal output is identical for L and R.

As the table shows, output 1 can be switched by control 1 only, and mute input is related to audio output 2 only.



Input/Output Interface

