

Nasab

External Rewinder

RW-91

ART.Nr: 95-50-22.

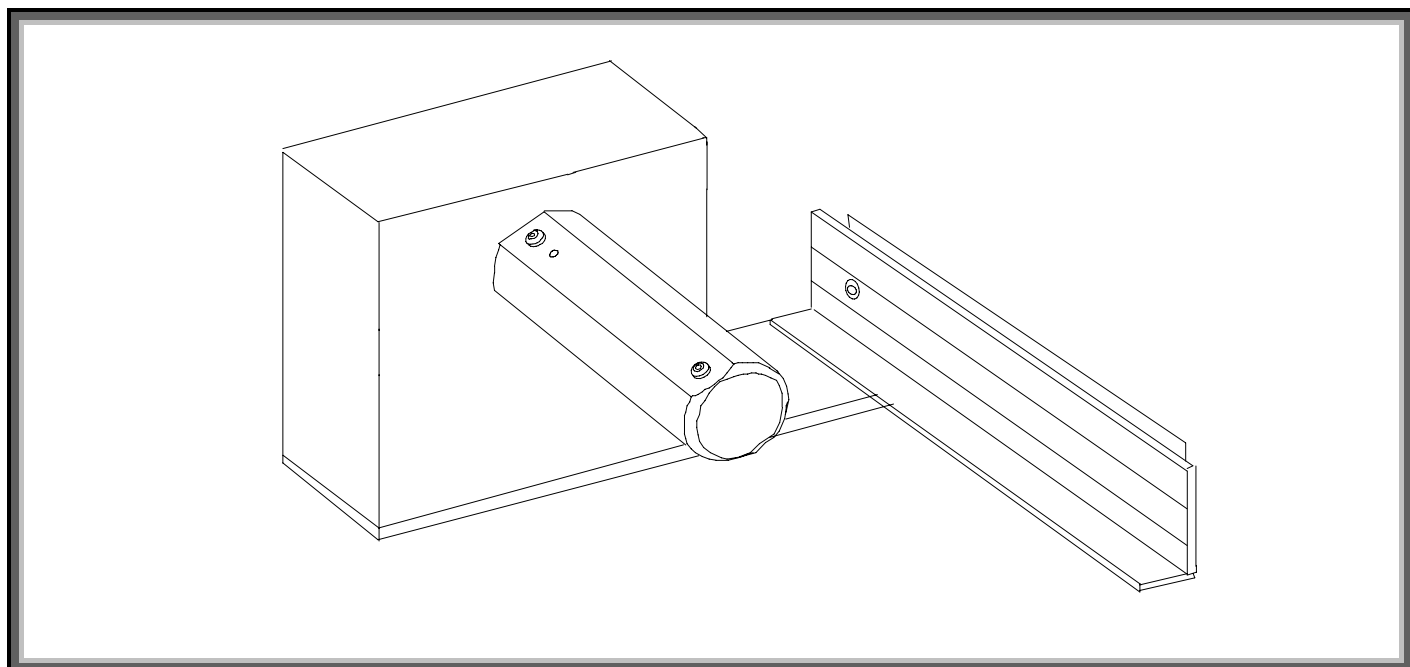

Service Manual.

Edition 1:1

December 1998 - Art. No. 10-50-22

INTRODUCTION

1. Introduction
2. Connection
3. Adjustment
4. Printing & Rewinding
5. Hints
6. Specification
7. Spares
8. Options
9. Elschema

Note:

18V/AC adapter is normally ordered separately

Connection:

- Put the printer on a table with enough space in front of it.
- Fit the rewinder in the front.
- Connect the Adapter with the cable from the 18V/AC input plug on the rewinder control panel to the power mains socket.
- Let the ON/OFF switch stay in OFF position.

Adjustment:

- Load the paper stock and thread the paper web inside the printer.
- Make sure that the roll and the web are properly inserted.
- Check carefully that it goes proper positioned along the guide washer.
- Check the web is close to the gable.
- Lower the printhead.
- Switch on the printer and Feed out a length of 40 cm of paper.
- Insert the bobbin on the rewinder shaft.
- Stretch the paper again and move the bobbin support wing so it becomes flush with inner side of the paper.

- For your information there is a friction clutch inside the rewinder.
- This friction clutch is adjustable by a knurled disk for certain specific rare cases.
- However the rewinder is proper adjusted for all media that printer is designed for.
- Use a full width paper core and insert it to the bobbin.
- Rewind manually a few turns so the paper is rewinded.

Note:

- The Bobbin has an adjustable plate. This plate can easily be moved by two screws so it fits the paper core.
- Move always the plate so it is aligned with the bobbin.
- If not a paper core is used there is enough space beneath the plate to insert the the web.

Printing & Rewinding

- Set the ON/OFF switch in ON position.
- Start to print the labels.

Hints:

- To get a perfect rewinded roll when printing batches of labels some points are suggested if possible. However the rewinder makes a good job without these proposals.
- In printers Setup use no “negative startadjust”. This will avoid retracting the label before printing.
- Check also in the Setup with Normal speed if printer still stops for each label.

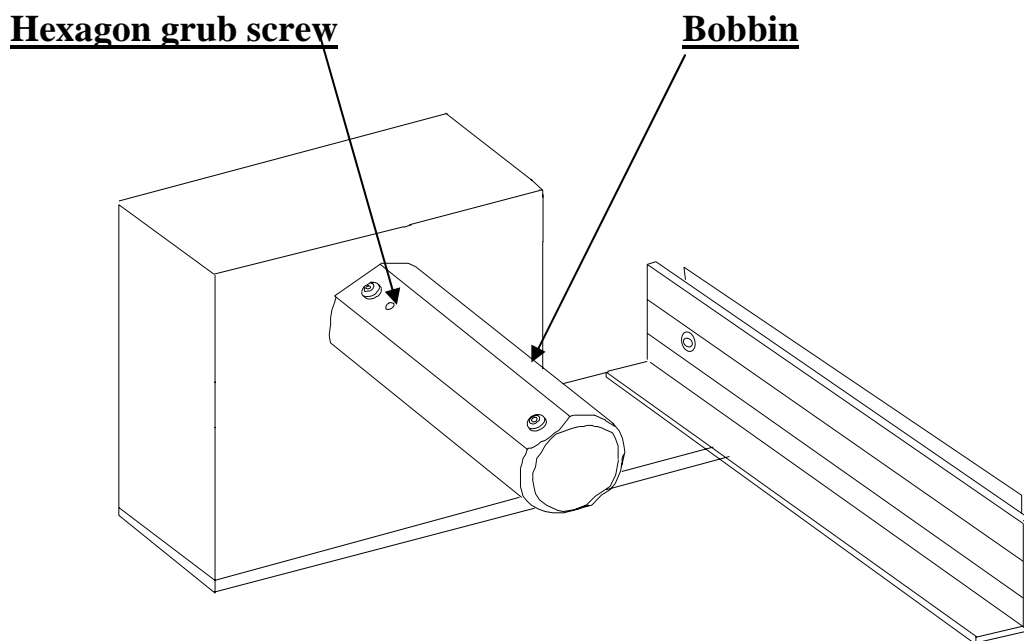

Specification:	Bobbin length,	125mm
	Label roll size,	38-180mm
	Bobbin paper core size	38-42mm

Dimensions:	L	180mm
	W	210mm
	H	200mm
	Weight	1.4kg

Power:

Supply the Rewinder from separate adapter either 18V/DC 15W, 800mA or 24V DC.
 (2 pole female chassi plug, length 12mm, outer 5,5mm, inner 2.1mm)

Powering from printer is not recommended.

Spare Parts:

Art. No.:	Model:
59-10-11	Friction Clutch
59-10-13	Motor assy
59-10-31	Shaft, motor-bobbin
59-20-10	Tubular belt
59-20-12	Bobbin including support wing
59-20-15	Ball Bearing (bobbin)
59-20-16	Support wing
59-20-20	Elektronik pc-board assy
59-20-21	Pulley (bobbin)
59-20-30	Metall plate bobbin
95-50-14	Adapter 230V/18 20VA

Options:

Adapter 76mm (3 ”) bobbin

95-50-20

Adapter 230V/18 15W

95-50-14

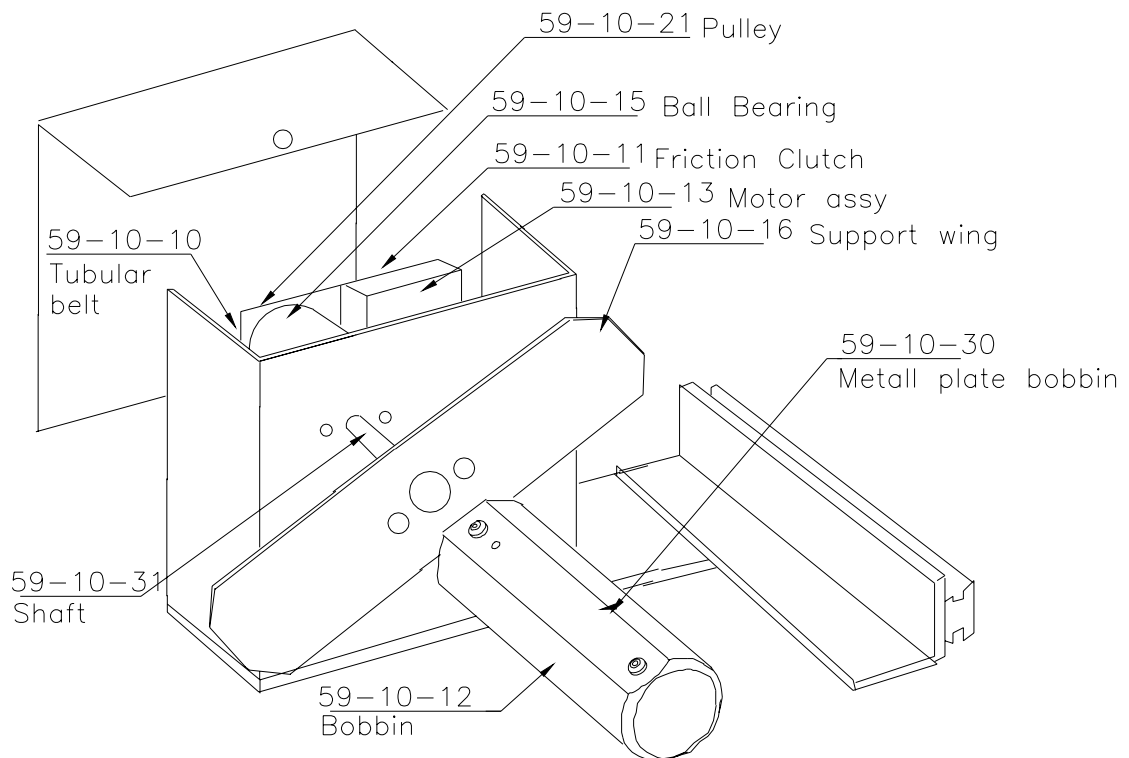

Elschema:

Layout

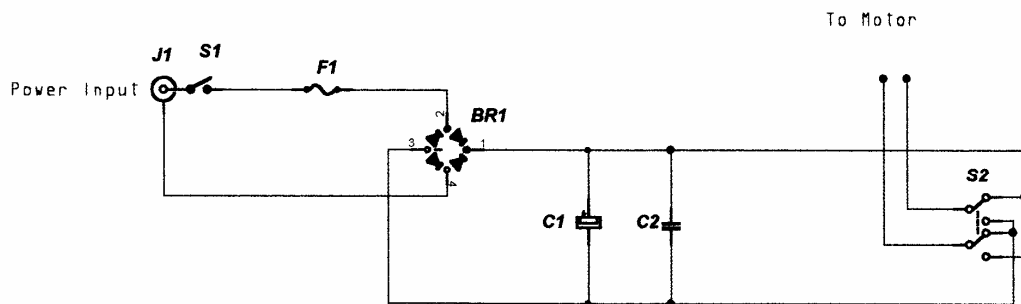
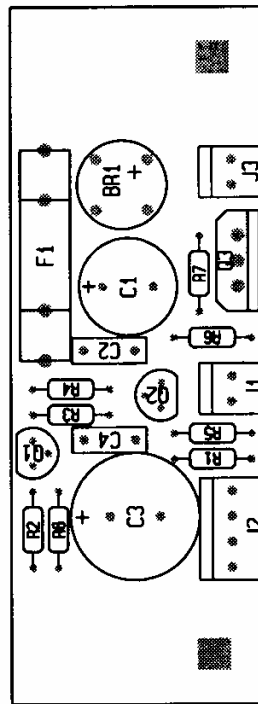

Nasab

Wichrowa 49
42 200 Czestochowa
Poland

Phone: +48(0)34 3654405
Fax: +48(0)34 3654489
Email: info@nasab.com